

Analysis on the Effectiveness of High Speed Printed Circuit Board Edge Radiated Emissions Based on Stimulus Source Location

Mark I. Montrose
 Montrose Compliance Services, Inc.
 2353 Mission Glen Dr.
 Santa Clara, CA 95051-1214
 mmontros@ix.netcom.com

Jin Hong-Fang, Er-Ping Li
 Institute of High Performance Computing
 1 Science Park Dr.
 #01-01 Singapore 117528
 engp1063@nus.edu.sg, eplee@ihpc.a-star.edu.sg

ABSTRACT

With increasing demand for higher operating frequencies, designers are faced with numerous obstacles during the design and layout of printed circuit boards (PCBs). One area of concern that a designer may not think about, or recognize during the analysis stage, is the effects of RF wave propagation between the power and return planes caused by digital circuits switching logic states while consuming a large amount of inrush surge current. This is becoming an important design issue that should be considered *prior* to final PCB layout.

The placement of components on a PCB and their physical distance to the edge of the assembly is the area of concern addressed in this paper, along with RF emissions that may propagate from the edge of the PCB causing potential harmful effects under specific operating conditions and configurations.

INTRODUCTION

In a typical high-density PCB, components are generally placed physically close to each other. The distance separation between a digital component consuming a significant amount of inrush surge current when transitioning I/O states simultaneously, and their physical location relative to the edge of a PCB can be cause for concern. In reality, we are dealing with signal integrity issues—planes acting as unterminated transmission lines containing ringing and reflections.

The physical distance between a digital component and the edge of the PCB is typically less than 3 cm maximum on a high-technology, multi-layer design containing multiple power and return planes. Also, today's technology is now in the GHz range. Research is performed to analyze wave propagation between the power and return planes at 900 MHz, 1.2 GHz and 2.45 GHz (wireless communication), and to validate use of the 20-H rule, proven to be a valid layout technique under certain conditions [1].

This paper provides insight into how field propagation exists within a high-density PCB for those without access to simulation software.

TRANSMISSION LINE THEORY

A transmission line must have a source path and return. Power distribution behaves in a similar manner.

Components consume DC power from a source (power) and use a return (ground). In reality, power/return planes are true transmission lines. For analogy purposes, a source driver sends a signal down a transmission line to a load. Beyond that load is another trace without termination (stub or PCB edge). The signal will return 100% to its source (reflection) when a high-impedance load is encountered. When components transition states, an electromagnetic field is propagated to the edge of the PCB through the dielectric of the plane pair (stub or unterminated transmission line) reflecting back to its source [2].

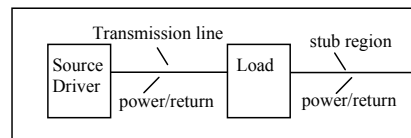

Top down view of component placements on a PCB

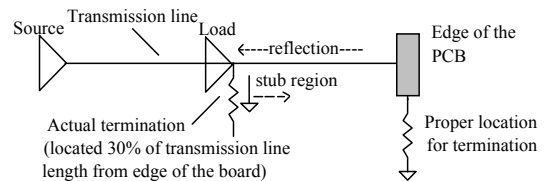

Transmission line representation of power and return planes

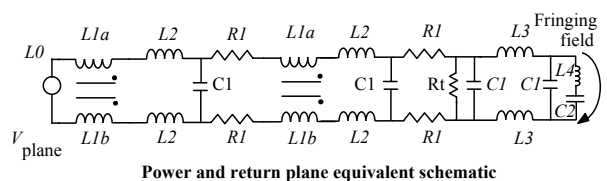

Power and return plane equivalent schematic

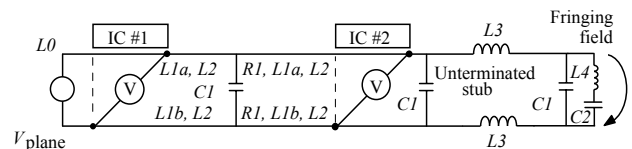

Power and ground plane mechanical equivalent representation

- $L1a$ and $L1b$ = mutual inductance termination
- $L2$ = line inductance intrinsic and residual after flux cancellation
- $L3$ = uncanceled inductance of the stub-no controlled image flux
- $C1$ = line capacitance
- Rt = partial termination, usually 10 times the impedance of the line
- $L4$ and $C2$ = possible fringing field at unterminated end of the planes

Fig. 1. PCB planes as a lossless transmission line [2]

Under this condition, the propagating wave must return to its source through a low-impedance path (i.e., free space vs. the PCB dielectric). This stub emulates an antenna where the last load [component] on the transmission lines provides the voltage driven source to the driven leg of the antenna and the return plane behaves as the ground, detailed in Fig. 1 [2].

TEST CONFIGURATION

A PCB was created that represents a typical high-density, multi-layer assembly with multiple planes, namely one power plane and several return planes. The configuration of this PCB is shown in Figure 2 as a 10-layer assembly. Previously published papers attempting to simulate the 20-H rule used only a single power and return plane in a two- or four-layer configuration without protection of shield planes above and below the power/return pair.

Without protection of shield planes, or appropriate plane edge terminations, the 20-H Rule can allow increased propagation of RF energy into the environment in the z-axis due to a patch antenna being designed into the PCB. In a multi-layer assembly, engineers should be interested "only" in the x- and y-axis of field propagation off the edge of the PCB.

A patch antenna is always resonant at a particular operating frequency of switching digital circuits, generally at that one frequency that causes concerns related to legally mandated regulatory emission requirements.

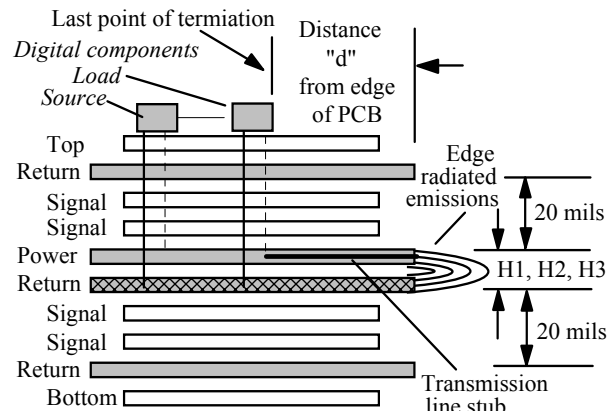

Note: The stimulus source is the last load on a transmission line. Distance "d" to edge of PCB represents an unterminated stub trace in regard to the power and return plane.

Fig. 2. Stripline configuration used for analysis

Figure 3 illustrates the physical structure that is used to perform simulation analysis.

To ensure a thorough analysis is investigated that properly represents PCB board edge radiated emissions based on physical location of a stimulus source, and to validate that anomalies are not present, the following

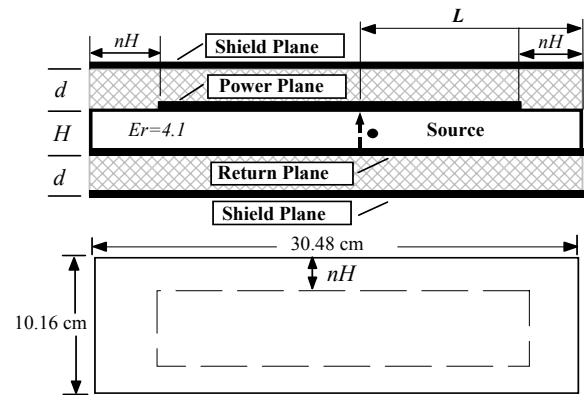

Figure 3. Simulation model

81 configurations are examined in matrix mode. Due to the massive amount of information desired, and performing simulation within the GHz range using full-wave 3-D FDTD, use of a parallel-processor supercomputer was mandatory.

Distance spacing between source and PCB edge:

13, 20 and 70 mm (0.5, 0.8 and 2.8 inches)

Distance spacing between power and return plane:

0.13, 0.26 and 0.52 mm (5, 10 and 20 mils)

Distance between power/return and shield planes

0.5 mm (0.02 inches or 20 mils)

Dimension of the PCB for all configurations:

30.48 cm x 10.16 cm (12 x 4.0 inches)

Stimulus frequency: 900 MHz, 1.2 GHz and 2.45 GHz

Stimulation Source: Line voltage source (1-Volt amplitude) connected between the power and return plane in sinusoidal form [Eq (1)].

$$E_{source} = \sin(2\pi kdt)/H \quad (V/m) \quad (1)$$

where: f = frequency, k = number of FDTD time steps, H = distance separation, dt = a single FDTD time step:

$$dt = 0.4294 \text{ ps for } H1 = 0.13 \text{ mm};$$

$$dt = 0.8345 \text{ ps for } H2 = 0.26 \text{ mm};$$

$$dt = 1.5097 \text{ ps for } H3 = 0.52 \text{ mm};$$

The reason why we chose high frequencies instead of lower frequencies, commonly found in academic research (i.e., 10 MHz), is due to *real-world* applications of high-technology products using multi-layer PCBs. The physical location of digital component, in relation to the edge of the PCB, is generally less than 3 cm. Simulation for signal integrity (SPICE) is frequently performed for GHz transmission lines, yet analysis using FDTD is rarely conducted due to the need for extensive computing power, memory requirements and compute time.

The advantage of investigating a stripline configuration over microstrip is that propagating fields between the power and return plane pair are confined

to between these two planes, without coupling flux to other planes at a significant physical distance away (above or below). Although a 10- and 20-mil distance separation between power and return is not realistic for a 10-layer assembly (5-mils between plane pairs is however common), these two additional dimension are used to examine the magnitude of board edge radiated emissions based on distance spacing between the power and return planes only, *relative* to the physical location of a stimulus source (provides additional data for accuracy of analysis).

Because a large number of configurations were examined, and the fact that the resultant near-field propagating wave cannot be realistically measured in the far-field inside an anechoic chamber with any level of accuracy, confirmation of test results with a physical PCB is not possible. The software program, a customized version of 3-D FDTD with integrated SPICE is proprietary to the authors, and is known accurate due to extensive commercial use by government and private industry researchers.

ANALYSIS OF TEST RESULTS

We investigated three different frequencies of stimulus, relative to the physical distance to the PCB edge. All PCBs have an intrinsic self-resonant frequency that had an affect on simulated results.

To determine if there were any anomalies or resonances, numerous simulations were performed and tabulated. This permits an accurate statement regarding the 20-H rule. Configurations include multiple distance spacing between the power/return planes and various configurations of an extended return plane (i.e., x-H Rule).

The Poynting vector is defined as electromagnetic (EM) power density, expressed by Eq. (2).

$$P = \mathbf{E} \times \mathbf{H} \text{ (watts/m}^2\text{)} \quad (2)$$

where \mathbf{E} and \mathbf{H} denotes electric and magnetic field strength respectively.

Tables 1, 2 and 3 detail the magnitude of the EM field (Poynting power) directly at the “physical edge of the PCB.” This calculated power density is a true Poynting vector (\mathbf{ExH}). Our customized version of FDTD permits accurate determination of \mathbf{ExH} at the same point in time and space. Table 1 has the stimulus source 1.3 cm from the edge of the PCB while Table 2 is at 2 cm. Table 3 has its stimulus at 7 cm.

To help understand our data, we use total power (watts) instead of power density (watts/m²), which is more meaningful to a designer. The propagated energy from the enclosed surface, used to create the plots herein, is the double integration of the Poynting power at the surface, Eq. (3). We now calculate the *total power with respect to time*, which is the primary area of interest using Eq. (4), shown in Tables 1-3.

Table 1. Radiated energy density: $L=13 \text{ mm or } 1.3 \text{ cm}$

Freq. (MHz)	x-H Rule	Distance between planes		
		Total power (1.0^{-12} watts [picowatts])		
		1.3 mm (5 mils)	2.6 mm (10 mils)	5.2 mm (20 mils)
900	0-H	384.14	168.38	96.97
	10-H	195.72	137.10	90.30
	20-H	195.06	117.11	90.30
1200	0-H	343.19	151.51	79.39
	10-H	202.30	130.03	74.69
	20-H	202.11	130.03	74.69
2450	0-H	40.93	6.91	1.21
	10-H	34.74	6.87	1.27
	20-H	35.38	6.87	1.27

Table 2. Radiated energy density: $L=20 \text{ mm or } 2.0 \text{ cm}$

Freq. (MHz)	x-H Rule	Distance between planes		
		Total power (1.0^{-12} watts [picowatts])		
		1.3 mm (5 mils)	2.6 mm (10 mils)	5.2 mm (20 mils)
900	0-H	270.20	118.03	67.84
	10-H	137.28	95.97	63.17
	20-H	137.02	95.97	63.17
1200	0-H	169.90	73.46	38.07
	10-H	99.30	62.76	35.80
	20-H	99.08	62.76	35.80
2450	0-H	24.15	3.73	0.70
	10-H	20.34	3.99	0.76
	20-H	21.01	3.99	0.76

Note: Bold face numbers supported by plots in Fig. 5.

Table 2. Radiated energy density: $L=70 \text{ mm or } 7.0 \text{ cm}$

Freq. (MHz)	x-H Rule	Distance between planes		
		Total power (1.0^{-12} watts [picowatts])		
		1.3 mm (5 mils)	2.6 mm (10 mils)	5.2 mm (20 mils)
900	0-H	383.92	171.21	99.79
	10-H	199.20	140.88	93.32
	20-H	199.20	140.88	93.32
1200	0-H	446.26	208.28	111.70
	10-H	272.70	181.58	105.55
	20-H	272.60	62.76	105.55
2450	0-H	107.21	16.23	2.46
	10-H	88.64	15.18	2.44
	20-H	88.76	15.18	2.44

$$P(t) = \iint_S P ds \quad (3)$$

$$P(\text{total}) = \int_T P(t) dt \quad (4)$$

Radiated power is the integration of the power density along edges AB, BC, CD and DA (Fig. 4) [1].

Because dt is extremely small, about 1 ps, the total amount of RF energy will also be small with respect to time. The advantage of doing time domain analysis allows us to understand field propagation behavior as

measured by a spectrum analyzer or receiver, related to regulatory limits or EMI to adjacent assemblies.

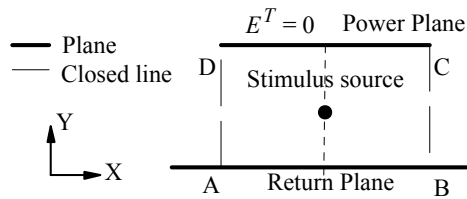

Figure 4. PCB structure for calculation Poynting vector

Note that the magnitude of radiated power in Tables 1-3, in the x - and y -axis, is in *picowatts*! We are not interested in z -axis or field propagation since the power/return plane pair has shield planes both above and below to capture this flux when configured as a patch antenna internal to a multi-layer PCB (stripline topology). With this extremely low level of radiated energy in the x - and y -axis, it is nearly impossible to measure the “true” value of the plane wave in an anechoic chamber in the far field (which includes measurement uncertainty), and make a conclusion as to whether the RF field propagating from the physical edge of a PCB complies with regulatory emission requirements or limits, or if the 20-H rule works.

For each simulation, we use 50,000 timesteps ($50,000 * dt$). In the $P(t)$ distribution plots, Figure 6 is provided to justify the data in Tables 1-3, and to allow us the opportunity to visually see how the propagated RF field appears under different configuration. The difference in configurations is due to the intrinsic self-resonant frequency of the PCB assembly in relation to the stimulus frequency and its corresponding wavelength. The plots of Figure 6 have different amplitude scales which makes it difficult to analyze thus, tabulated average power provide greater benefit of understanding (Tables 1-3).

It is unrealistic to plot contour lines of Figure 5 for both E and H fields simultaneously and make a statement regarding use of the 20-H Rule. Use of the Poynting power is required (Figure 6).

Due to the nature of the original plots in color, and three configurations per plot, attempting to ascertain which trace belongs to 0-H, 10-H and 20-H is not graphically possible. However, the numeric values of the average power calculated by Eq. (4) are listed in Tables 1-3. Matlab is used to convert numerical data from FDTD simulation into graphical form.

Figure 5 shows a sample of field plots illustrating both E and H propagating fields. For accuracy of analysis, the electric field (E) and magnetic field (H) are computed separately. Results of both fields were then integrated per Eq. (3) to create the plots in Figures 6. Figure 6 represents the true Poynting power vector of RF energy present. It is this RF field that can cause, through near-field coupling, harmful interference or

EMI to adjacent assemblies located in close proximity to the edge of the PCB.

SUMMARY

This paper analyzes both time and frequency domain components of a propagating wave that exist between power and return planes based on physical stimulus location of a digital component requiring significant inrush current during logic switching cross-conduction.

When consideration is made for implementing the 20-H rule, the item of importance is the magnitude of the Poynting power at a particular point in time in the x - and y -axis. One cannot simulate either the electric (E) or magnetic (H) field independently and come to a conclusion on the performance or benefits of the 20-H design rule.

Board resonances and physical dimensions play a significant role in the effectiveness of the 20-H rule. It is apparent that this rule-of-thumb has several caveats that must be recognized by those who understand why we need this rule and under what condition benefits are achieved when properly implemented [1].

1. The magnitude of radiated power will increase or decrease depending on physical location of the stimulus from the edge of the PCB. For this series of test, 2 cm provided the least amount of radiated power, whereas 1.3 and 7 cm had increased emissions. The wavelength of the signal in the unterminated transmission line (planes) affects board resonances related to the stimulus source.
2. In general, lower frequencies benefit from implementation of the x-H rule with close plane spacing (5 and 10 mils), also validated in [1]. At a greater distance spacing (20 mils) no benefit is realized, although lower levels of radiated power exist. This is due to shield planes being provided.
3. In general, higher frequencies do not require use of the x-H rule due to very small wavelengths inside the transmission line carrying a stimulus.
4. Board resonances will affect the magnitude of the radiated field, based on physical dimensions; plane separation, use of shield planes, stub length of unterminated transmission lines and stimulus frequency (distance to the edge of the PCB).

REFERENCES

- [1] Montrose, Mark I., Er-Ping Li, Wei-Liang Yuan, Jiang Yi, Li Le-Wei. 2002. “Analysis on the Effectiveness of the 20-H Rule Using Numerical Simulation Technique.” *IEEE International Symposium on Electromagnetic Compatibility*. pp. 329-333.
- [2] Montrose, Mark I. 2000. 2nd ed. *Printed Circuit Board Design Techniques for EMC Compliance—A Handbook for Designers*. NY: Wiley/IEEE Press.

Plots of E_x with $L=20$ mm, $H=0.13$ mm, $f=900$ MHz (worst case for this configuration – Table 2)

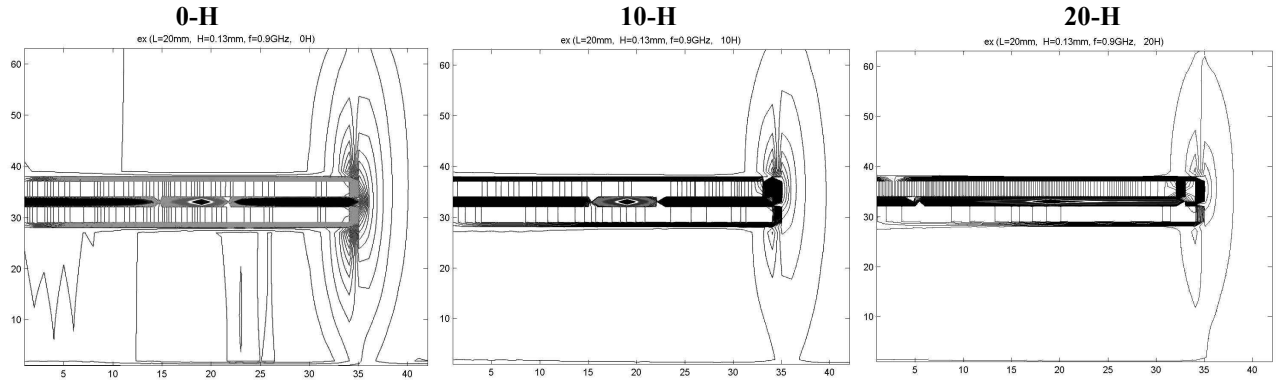

Plots of H_y with $L=20$ mm, $H=0.13$ mm, $f=900$ MHz (worst case for this configuration – Table 2)

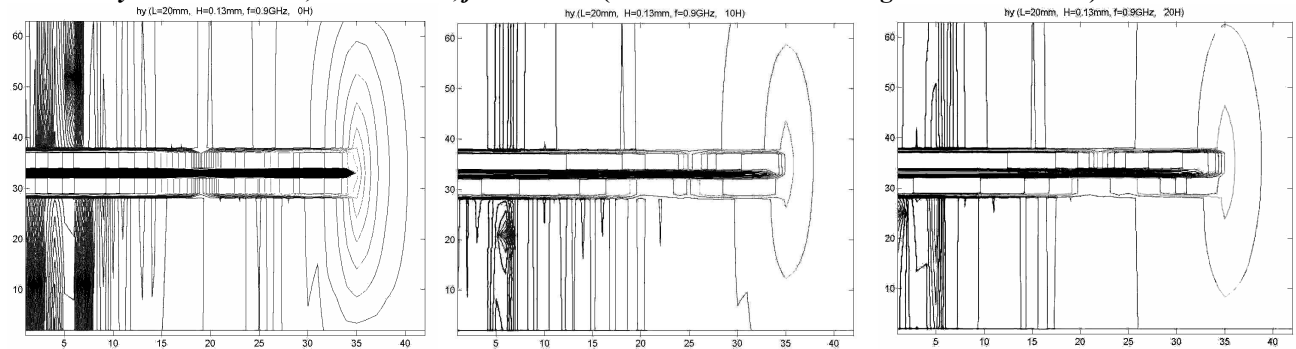

Plots of E_x with $L=20$ mm, $H=0.52$ mm, $f=2.45$ GHz (best case for this configuration – Table 2)

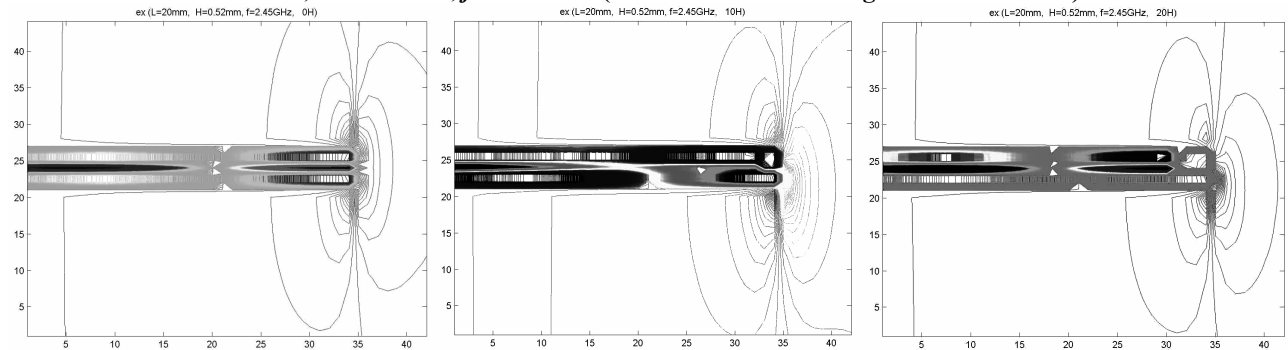

Plots of H_y with $L=20$ mm, $H=0.52$ mm, $f=2.45$ GHz (best case for this configuration – Table 2)

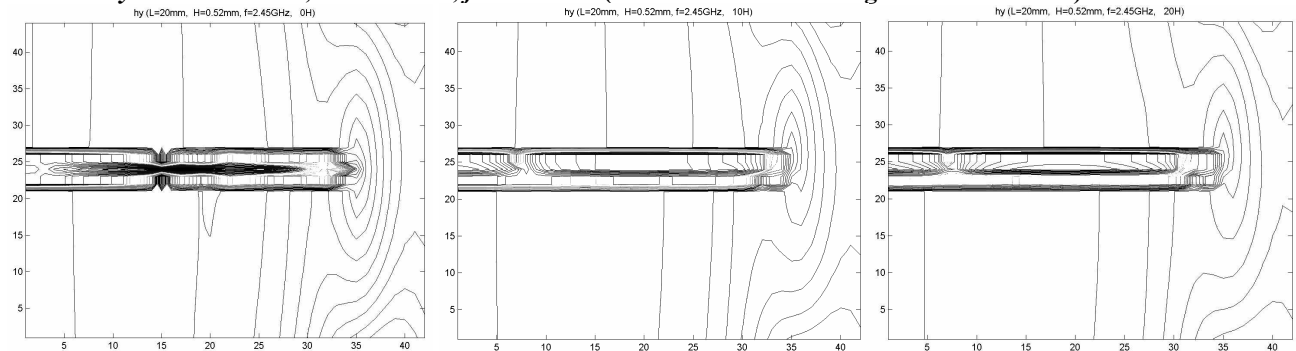
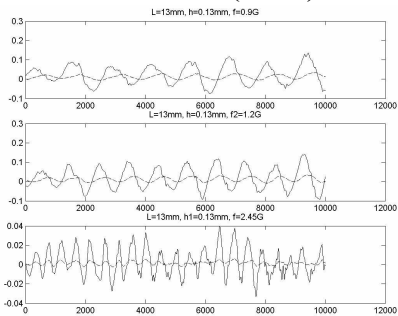
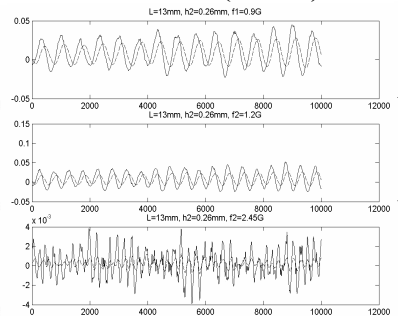

Figure 5. Contour field lines of the RF propagating field from the edge of the PCB: E and H field separately

Case: L=1.3 cm (13 mm)
H=0.13 cm (5 mils)



H=0.26mm (10 mils)



H=0.52mm (20 mils)

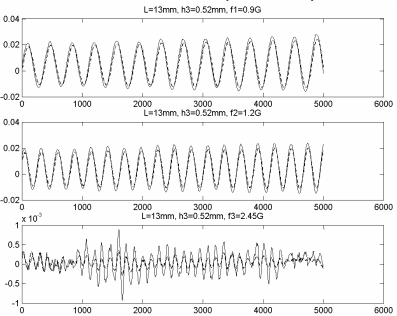

900 MHz

1.2 GHz

2.45 GHz

Case: L=2 cm (20 mm)
H=0.13 cm (5 mils)

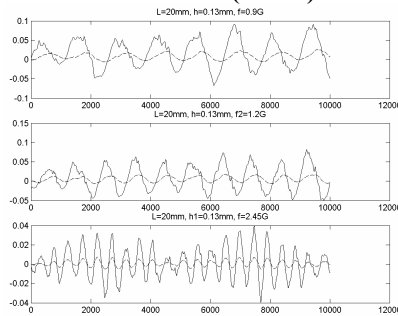

H=0.26mm (10 mils)

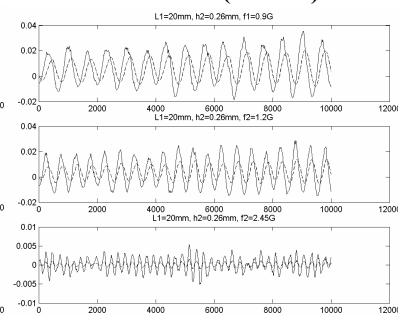

H=0.52mm (20 mils)

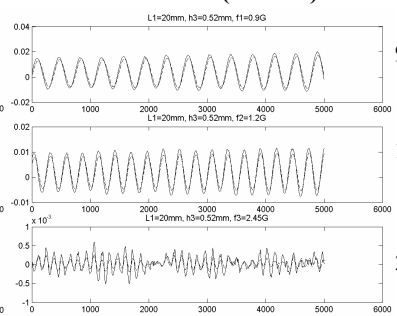

900 MHz

1.2 GHz

2.45 GHz

Case: L=7.0 cm (70 mm)
H=0.13 cm (5 mils)

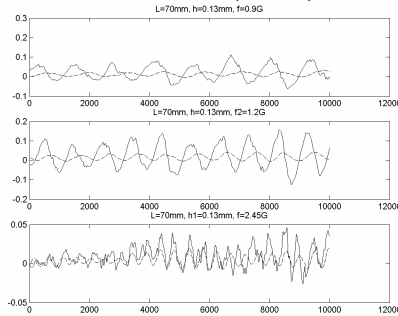

H=0.26mm (10 mils)

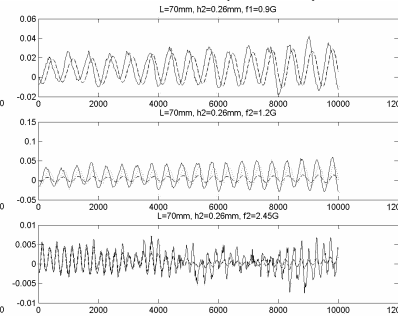

H=0.52mm (20 mils)

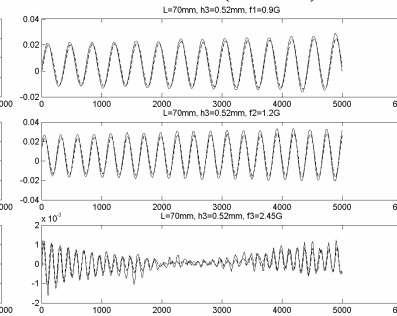

900 MHz

1.2 GHz

2.45 GHz

Figure 6. Poynting vector plots (for numerical data used in Tables 1, 2 and 3)

Note: Each plot contains 3 traces. Each trace displays 0-H, 10-H and 20-H (not able to view without difficulty)